

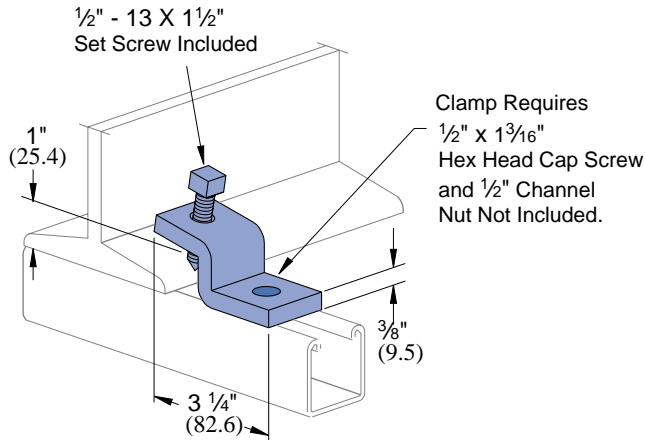

P1379S

Wt/100 pcs: 75 Lbs (34.0kg)



Channel Style	Design Load Each (Use in Pairs Only) Lbs (kg)
P1000	600 <i>272.2</i>
P1100	500 <i>226.8</i>
P2000	450

MATERIAL

Fittings, unless noted, are made from hot-rolled, pickled and oiled steel plates, strip or coil, and conform to ASTM specifications A575, A576, A635, or A36. The fitting steel also meets the physical requirements of ASTM A1011 SS GR 33. The pickling of the steel produces a smooth surface free from scale.

Many fittings are also available in stainless steel, aluminum and fiberglass. Consult factory for ordering information.

FINISHES

Fittings are available in: Perma-Green II (GR), electro-galvanized (EG), conforming to ASTM B633 Type III SC1; Hot-dipped galvanized (HG), conforming to ASTM A123 or A153 and plain (PL).

Project: _____

Approval Stamp:

Architect / Engineer: _____

Date: _____ **Phone:** _____

Contractor: _____

Address: _____

Notes 1: _____

Notes 2: _____